

CHIP-8 Electronics Training

WWW.CHIP-8.COM

eBook: Digital Electronics, Revision 1.0.3

Digital Electronics encompasses a large range of electronic components that have a commonality of operation at two specific logic levels. The two levels being a logic Low state (False condition) or logic High state (True condition). A logic Low can be also be represented by a '0' designation and a logic High by a '1' designation. This is called Positive logic. Positive logic is always inferred unless stated otherwise.

When Negative logic is being used, the logic states are inverted. A logic Low is represented by a '1' state and a logic High by a '0' state. The use of Negative logic provides some design advantages, and an alternative way of looking at a circuit when active low signals are being dealt with.

TTL (Transistor-Transistor-Logic) levels range between 0 and 5V DC. A logic Low State has a DC Voltage between 0V and 0.8V. A logic High State has a DC Voltage between 2.4V and 5V. The voltage range between the Low and High States is called the undefined region, or Tri-state area. When a logic gate is tri-stated, its output floats. This means that it has a High impedance, and thus doesn't provide any valid logic levels during this time. If needed, the use of Pull up (PUP) or Pull down Resistors can provide default logic levels for this condition.

CMOS (Complementary Metal Oxide Semiconductor) logic levels are 0V to 1/3 VCC for a logic Low state, and 2/3 VCC to VCC for a logic High state. VCC is usually a Voltage in the range of 5V to 15V DC.

A Logic Probe provides the simplest method for validating TTL and CMOS logic levels.

Attention: *No part of this Training Material shall be reproduced, stored in a computer retrieval system, or transmitted by any means, electronic, mechanical, photocopying, recording or otherwise, without prior express permission from www.CHIP-8.com*

While every precaution has been taken in the preparation of this material, no responsibility will be assumed for errors or omissions. Neither is any liability assumed for damages resulting from the use of any information contained herein.

Number Systems

Binary

This is a base 2 number system. Each digit (having two states) increases its weighting by two as it progresses from LSB (Least Significant BIT) to MSB (Most Significant BIT). The LSB is always on the right (BIT 0). This progression is shown below.

BIT	D7	D6	D5	D4	D3	D2	D1	D0
Base 2 value	2^7	2^6	2^5	2^4	2^3	2^2	2^1	2^0
Weighting	128	64	32	16	8	4	2	1

To find the decimal equivalent of a Binary Number simply add up the weighting values of the BIT's that are set to 1. For example, the Binary Number 01000001 is equal to 65 Decimal.

Binary Coded Decimal

Binary Coded Decimal (BCD) is a method of using Binary numbers to represent the decimal numbers from 0 to 9. Each decimal number is represented by four Binary digits, as shown below.

Decimal	BCD
0	0000
1	0001
2	0010
3	0011
4	0100
5	0101
6	0110
7	0111
8	1000
9	1001

It is important to be aware that Binary and BCD are not the same. To illustrate this, consider the decimal number 53. Its Binary equivalent is 00110101. In BCD this would be represented by the number 01010011.

Hexadecimal

This is a base 16 number system. The Characters 0 through F represent Decimal numbers 0 through 16. Each Hexadecimal digit is equivalent to 4 Binary digits, as shown below.

Hex	Binary	Decimal
0	0000	0
1	0001	1
2	0010	2
3	0011	3
4	0100	4
5	0101	5
6	0110	6
7	0111	7
8	1000	8
9	1001	9
A	1010	10
B	1011	11
C	1100	12
D	1101	13
E	1110	14
F	1111	15

In a CHIP-8 Computer - Hexadecimal numbers are used to represent Memory addresses, and Data. An example of this can be seen on the Status Bar of the Computer's Display. Here, a four digit Hexadecimal number is shown (4457) – representing the current memory address.



CHIP-8 Computer Display

The first digit (7), specifies the quantity of 1's that make up the number. Total = 7.

The second digit (5), specifies the quantity of 16's that make up the number. Total = 80.

The third digit (4), specifies the quantity of 256's that make up the number. Total = 1024.

The fourth digit (4), specifies the quantity of 4096's that make up the number.
Total=16,384.

Adding all totals together we get 17495. Therefore 4457 Hex=17495 Decimal.

The Binary equivalent to 4457 Hex is: 0100010001010111.

Data Width

A 'BIT' is an acronym for a Binary Digit. It has only two states, namely 0 or 1.

A 'Nibble' consists of 4 BIT's of data.

A 'Byte' consists of 8 BIT's of data (2 Nibbles).

A 'Word' consists of 16 BIT's of data (2 Bytes).

A 'Long Word' consists of 32 BIT's of data (2 Words).

A 'Double Long Word' consists of 64 BIT's of data.

Logic Gates

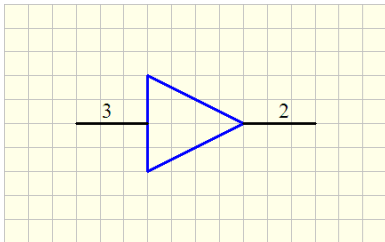

Buffer

TRUTH Table

Input 3	Output 2
0	0
1	1

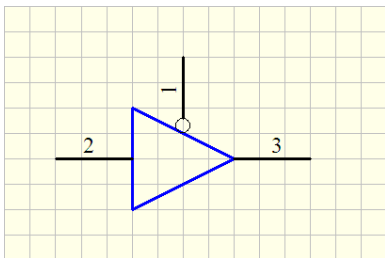

Buffer (Tri-State)

TRUTH Table

Control 1	Input 2	Output 3
1	X	Hi Z
0	0	0
0	1	1

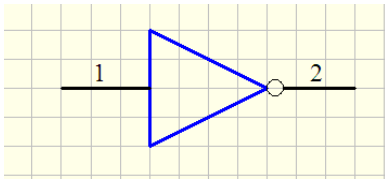

Inverter (NOT gate)

TRUTH Table

Input 1	Output 2
0	1
1	0

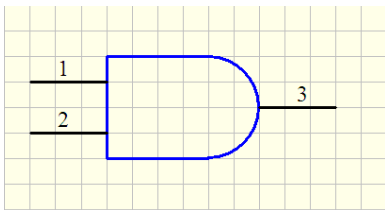

AND Gate

TRUTH Table

Input 1	Input 2	Output 3
0	0	0
0	1	0
1	0	0
1	1	1

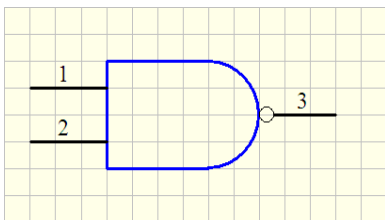

NAND Gate

TRUTH Table

Input 1	Input 2	Output 3
0	0	1
0	1	1
1	0	1
1	1	0

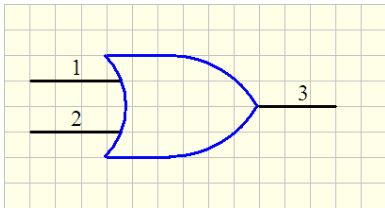

OR Gate

TRUTH Table

Input 1	Input 2	Output 3
0	0	0
0	1	1
1	0	1
1	1	1

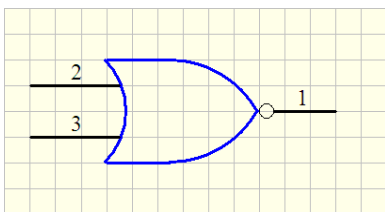

NOR Gate

TRUTH Table

Input 1	Input 2	Output 3
0	0	1
0	1	0
1	0	0
1	1	0

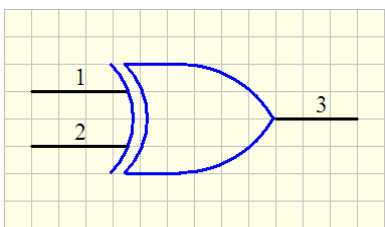

XOR Gate

TRUTH Table

Input 1	Input 2	Output 3
0	0	0
0	1	1
1	0	1
1	1	0

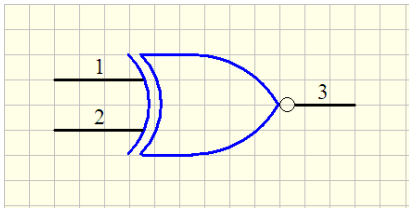

XNOR Gate

TRUTH Table

Input 1	Input 2	Output 3
0	0	1
0	1	0
1	0	0
1	1	1

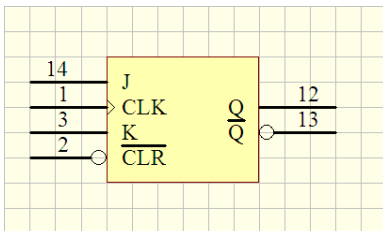

JK type FF

TRUTH Table

Clock	J	K	Clear	Q	Q bar
X	X	X	0	0	1
Rising Edge	0	0	1	Hold	Hold
Rising Edge	0	1	1	0	1
Rising Edge	1	0	1	1	0
Rising Edge	1	1	1	Toggle	Toggle
X	X	X	1	Unchanged	Unchanged

A JK FF can be used to make a D-type FF by inverting J and connecting it to the K input. The J input is now treated as the D input. On some JK Flip Flops the K input is already inverted, and it is a simple matter of connecting J and K bar together.

FF is an abbreviation for Flip-Flop. Another name for a Flip-Flop is a Latch, or less commonly- a Bistable Multivibrator.

An individual Flip Flop can only store 1 BIT of data. To hold a Byte of data would require 8 Flip Flops.

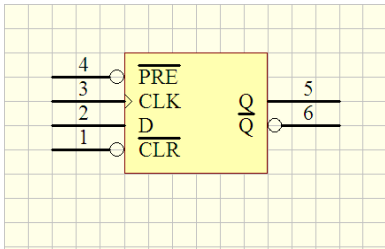

D-type FF

TRUTH Table

Clock	D	Preset	Clear	Q	Q bar
X	X	0	1	1	0
X	X	1	0	0	1
Rising Edge	0	1	1	0	1
Rising Edge	1	1	1	1	0
0	X	1	1	Unchanged	Unchanged

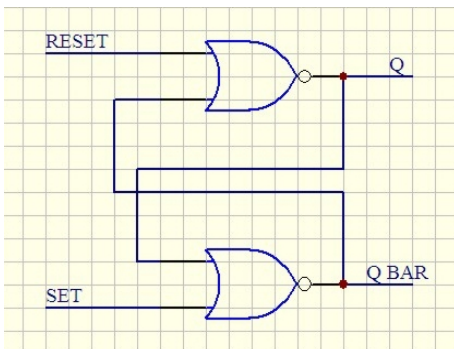

RS-type FF

TRUTH Table

RESET	SET	Q	Q Bar
0	0	No change	No change
0	1	1	0
1	0	0	1
1	1	Invalid (race)	Invalid (race)

By replacing the NOR gates with NAND gates, Reset and Set become active low inputs.

T- type FF

A T (Toggle) type Flip Flop is made up of a D-type FF with its D input connected to Q bar.

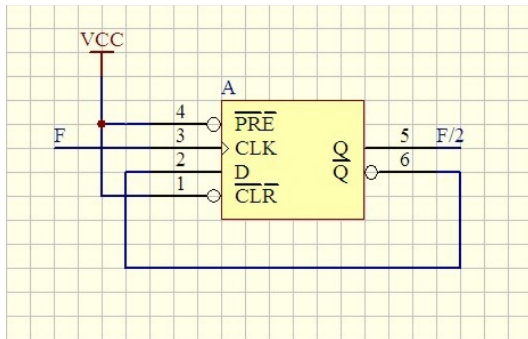

T-type FF

A T-type FF is extensively used in clock circuits (Digital and RF) as a fundamental way of dividing clock frequencies. The frequency fed into the clock input will be divided by two and output on Q. Q bar remains 180 degrees out of phase with Q.

This circuit is commonly cascaded to produce much lower clock frequencies than that originally produced. Such a circuit is sometimes referred to as a Prescaler. It scales the input frequency prior to a further operation. The circuit below shows how four T-type Flip Flops can be cascaded to produce an output frequency 1/8 lower than the applied frequency.

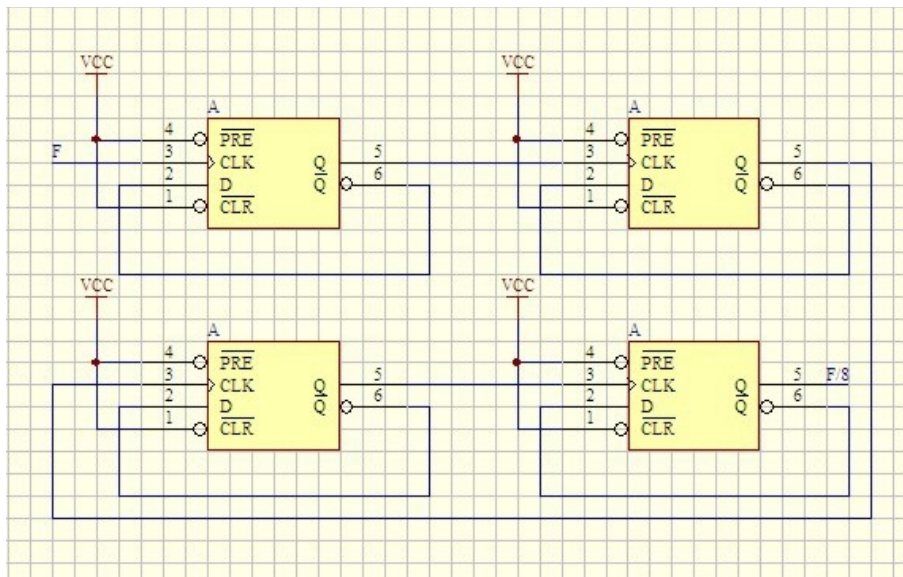

Prescaler circuit

Monostable

A Monostable multivibrator has one stable state. It is used to create a timing period of fixed duration in response to an external event. This circuit is also known as a 'one shot'.

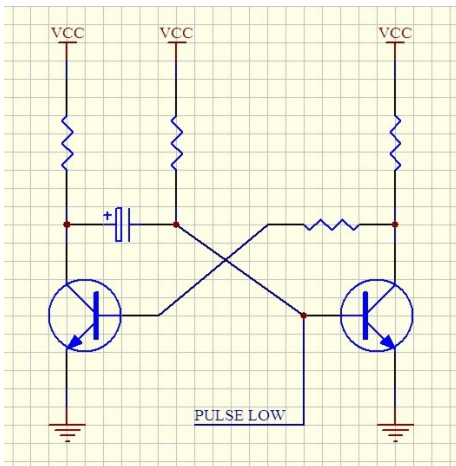

Bistable

A bistable multivibrator will remain in either state indefinitely. It functions as an RS Flip-Flop with active low Set and Reset inputs.

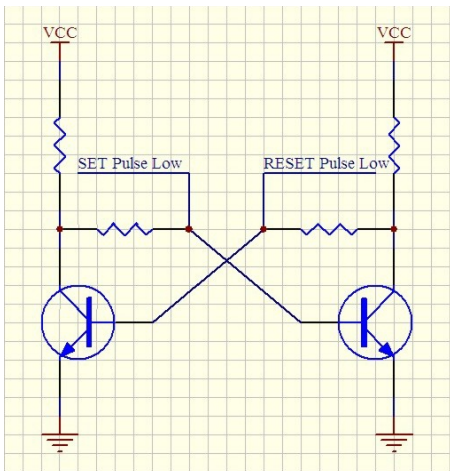

Microprocessors

A Microprocessor is a VLSI component, or circuit (in the case of discrete components) that reads binary data from a memory device, and then executes the data (in the form of opcodes) as an instruction to store, retrieve or manipulate. In its simplest form, it is a CPU (Central Processing Unit) with circuitry that allows memory to be accessed.

A CPU consists of three sub components, namely:

Registers. Registers are internal memory of fixed data widths (usually 8 or 16 Bits). They are used to hold retrieved instructions, instruction arguments, instruction results, program counter values, and the overall validity of the instruction operation (flags).

ALU (Arithmetic logic Unit). The ALU performs all basic computational operations: arithmetic, logical, and comparisons. Consists of adders, shifter, complement, and multiplier circuits.

CU (Control Unit). The CU co-ordinates the retrieval and execution of the stored opcodes.

A Microprocessor can loosely be referred to as a Processor, MCU (Microprocessor Control Unit), or even CPU (Central Processing Unit). When spoken of, most people interchange the terms. Another similar term is Microcontroller. This is a Microprocessor with several external peripherals electrically attached to it. The peripherals can be I/O, RAM, ROM, Flash memory, Timers and Counters, Watchdog timers, Reset generators and Monitors etc.

A Microcontroller provides extra functionality with a small chip count (usually 1). It often makes more sense to use a Microcontroller in electronic designs when circuit simplicity and PCB size are important. The CHIP-8 Computer is a good example of this.

Memory

Memory Integrated Circuits (IC's) come in two basic forms, namely Static and Dynamic types. Static Memory retains its data until the Power Supply is removed. This type of memory is normally referred to as SRAM. Dynamic Memory will also lose its data if the Power Supply is removed, or if Refresh cycles are not maintained. Memory refresh is achieved by the application of two active control lines called RAS (Row Address Strobe), and CAS (Column Address Strobe). This type of memory is normally referred to as DRAM. Both types of memory are called Volatile Memory. When Memory is able to retain its data after Power is removed it is referred to as Non Volatile Memory. Examples of this type of memory are BBRAM, ROM, and Flash Memory.

BBRAM is an acronym for Battery Backed RAM.

DRAM is an acronym for Dynamic RAM.

EPROM is an acronym for Erasable Programmable ROM.

EEPROM or **E²PROM** are acronyms for Electrically Erasable Programmable ROM.

PROM is an acronym for Programmable ROM.

RAM is an acronym for Random Access Memory.

ROM is an acronym for Read Only Memory.

SRAM is an acronym for Static RAM.

Another acronym that is commonly used, when dealing with memory IC's is **OTP** (One Time Programmable). A ROM and a PROM are both OTP devices. Once programmed with data they can not be erased, and will normally be replaced if the data needs to be significantly changed.

ADC

ADC is an abbreviation for Analog to Digital Converter. It is also referred to as an A to D Converter. Its function is to convert an Analog Signal to a Digital signal (usually an 8 or 12 BIT device). The width of the internal ADC data bus determines the resolution of the device. An 8 bit ADC will have 256 quantization steps, a 12 BIT device will have 4096, and a 16 BIT device will have 65536. The ADC resolution is important because a device with a higher resolution is able to differentiate between smaller Analog Input changes. There are also serial versions available that have a built in shift register after the ADC. This reduces the pin count of the component dramatically, and helps simplify the interface, particularly when utilizing small Microcontrollers. The Analog input voltage range is normally specified at 0 to 5VDC, however some devices support differential voltages -2.5 to +2.5VDC. Video specific devices are scaled to a 0 to +1VDC range. Industrial devices are often scaled to a 0 to 10VDC range.

Another important ADC attribute is its Sampling frequency. This has a direct relationship to the Input Signals Bandwidth (BW). The Sampling frequency must stay higher than twice the Bandwidth (Nyquist theorem) to attain a reasonable interpretation of the input signals waveform characteristics.

An ADC requires a Reference Voltage to operate. This is usually a Precision Voltage Regulator. A +2.5VDC source is common, which is either internally or externally generated.

DAC

DAC is an abbreviation for Digital to Analog Converter. It is also referred to as a D to A Converter. Its function is to convert a Digital Signal to an Analog signal (usually an 8 BIT device). The width of the internal ADC data bus determines the resolution of the device. An 8 bit ADC will have 256 quantization steps, a 12 BIT device will have 4096, and a 16 BIT device will have 65536. The ADC resolution is important because a device with a higher resolution is able to provide a smaller voltage change on the output. The Analog Output voltage range is normally specified as 0 to 5VDC, however for Video applications 0 to +1VDC is used, and in Industrial Applications 0 to 10VDC is common.

Questions & Answers

The answers are highlighted in yellow.

1. Why are special precautions necessary in handling FET and CMOS devices?
 - A. They have fragile leads that may break off.
 - B.** They are susceptible to damage from static charges.
 - C. They have micro-welded semiconductor junctions that are susceptible to breakage.
 - D. They are light sensitive.
2. What do the initials CMOS stand for?
 - A. Common mode oscillating system.
 - B. Complementary mica-oxide silicon.
 - C.** Complementary metal-oxide semiconductor.
 - D. Complementary metal-oxide substrate.
3. What is the voltage range considered to be valid logic low input in a TTL device operating at 5 volts?
 - A. 2.0 to 5.5 volts.
 - B. -2.0 to -5.5 volts.
 - C.** Zero to 0.8 volts.
 - D. 5.2 to 34.8 volts.
4. What is the voltage range considered to be a valid logic high input in a TTL device operating at 5.0 volts?
 - A.** 2.0 to 5.0 volts.
 - B. 1.5 to 3.0 volts.
 - C. 1.0 to 1.5 volts.
 - D. 5.2 to 34.8 volts.
5. What is the common power supply voltage for TTL series integrated circuits?
 - A. 12 volts.
 - B. 13.6 volts.
 - C. 1 volt.
 - D.** 5 volts.
6. TTL inputs left open develop what logic state?
 - A.** A high-logic state.
 - B. A low-logic state.
 - C. Open inputs on a TTL device are ignored.
 - D. Random high- and low-logic states.

7. Which of the following instruments would be best for checking a TTL logic circuit?
 - A. VOM.
 - B. DMM.
 - C. Continuity tester.
 - D.** Logic probe.

8. What do the initials TTL stand for?
 - A. Resistor-transistor logic.
 - B.** Transistor-transistor logic.
 - C. Diode-transistor logic.
 - D. Emitter-coupled logic.

9. What is a characteristic of an AND gate?
 - A. Produces a logic "0" at its output only if all inputs are logic "1".
 - B.** Produces a logic "1" at its output only if all inputs are logic "1".
 - C. Produces a logic "1" at its output if only one input is a logic "1".
 - D. Produces a logic "1" at its output if all inputs are logic "0".

10. What is a characteristic of a NAND gate?
 - A. Produces a logic "0" at its output only when all inputs are logic "0".
 - B. Produces a logic "1" at its output only when all inputs are logic "1".
 - C. Produces a logic "0" at its output if some but not all of its inputs are logic "1".
 - D.** Produces a logic "0" at its output only when all inputs are logic "1".

11. What is a characteristic of an OR gate?
 - A.** Produces a logic "1" at its output if any input is logic "1".
 - B. Produces a logic "0" at its output if any input is logic "1".
 - C. Produces a logic "0" at its output if all inputs are logic "1".
 - D. Produces a logic "1" at its output if all inputs are logic "0".

12. What is a characteristic of a NOR gate?
 - A. Produces a logic "0" at its output only if all inputs are logic "0".
 - B. Produces a logic "1" at its output only if all inputs are logic "1".
 - C.** Produces a logic "0" at its output if any or all inputs are logic "1".
 - D. Produces a logic "1" at its output if some but not all of its inputs are logic "1".

13. What is a characteristic of a NOT gate?
 - A. Does not allow data transmission when its input is high.
 - B.** Produces a logic "0" at its output when the input is logic "1" and vice versa.
 - C. Allows data transmission only when its input is high.
 - D. Produces a logic "1" at its output when the input is logic "1" and vice versa.

14. Which of the following logic gates will provide an active high out when both inputs are active high?
- A. NAND.
 - B. NOR.
 - C. AND.**
 - D. XOR.
15. In a negative-logic circuit, what level is used to represent a logic 0?
- A. Low level.
 - B. Positive-transition level.
 - C. Negative-transition level.
 - D. High level.**
16. For the logic input levels shown in Figure 3E12, what are the logic levels of test points A, B and C in this circuit? (Assume positive logic.)
- A. A is high, B is low and C is low.
 - B. A is low, B is high and C is high.**
 - C. A is high, B is high and C is low.
 - D. A is low, B is high and C is low.

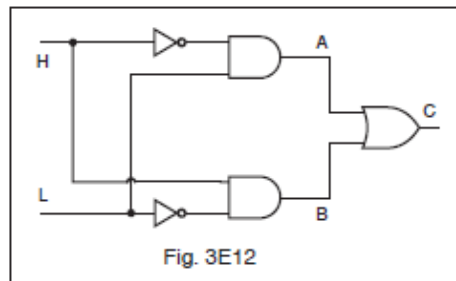

17. For the logic input levels given in Figure 3E13, what are the logic levels of test points A, B and C in this circuit? (Assume positive logic.)
- A. A is low, B is low and C is high.
 - B. A is low, B is high and C is low.
 - C. A is high, B is high and C is high.**
 - D. A is high, B is low and C is low.

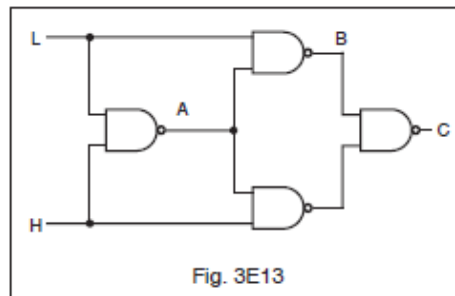

18. In a positive-logic circuit, what level is used to represent a logic 1?

- A. High level
- B. Low level
- C. Positive-transition level
- D. Negative-transition level

19. Given the input levels shown in Figure 3E14 and assuming positive logic devices, what would the output be?

- A. A is low, B is high and C is high.
- B. A is high, B is high and C is low.
- C. A is low, B is low and C is high.
- D. None of the above are correct.

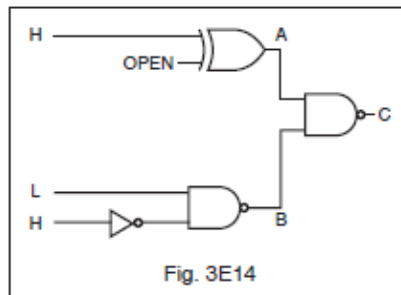

20. What is a truth table?

- A. A list of input combinations and their corresponding outputs that characterizes a digital device's function.
- B. A table of logic symbols that indicate the high logic states of an op-amp.
- C. A diagram showing logic states when the digital device's output is true.
- D. A table of logic symbols that indicates the low logic states of an op-amp.

21. A flip-flop circuit is a binary logic element with how many stable states?

- A. 1
- B. 2
- C. 4
- D. 8

22. What is a flip-flop circuit? A binary sequential logic element with ___ stable states.

- A. 1
- B. 4
- C. 2
- D. 8

23. How many flip-flops are required to divide a signal frequency by 4?

- A. 1
- B. 4
- C. 8
- D. 2

24. How many bits of information can be stored in a single flip-flop circuit?
- A. 1
 - B. 2
 - C. 3
 - D. 4
25. How many R-S flip-flops would be required to construct an 8 bit storage register?
- A. 2
 - B. 4
 - C. 8
 - D. 16
26. An R-S flip-flop is capable of doing all of the following except:
- A. Accept data input into R-S inputs with CLK initiated.
 - B. Accept data input into PRE and CLR inputs without CLK being initiated.
 - C. Refuse to accept synchronous data if asynchronous data is being input at same time.
 - D. Operate in toggle mode with R-S inputs held constant and CLK initiated.
27. The frequency of an AC signal can be divided electronically by what type of digital circuit?
- A. Free-running multivibrator.
 - B. Bistable multivibrator.
 - C. OR gate.
 - D. Astable multivibrator.
28. What is an astable multivibrator?
- A. A circuit that alternates between two stable states.
 - B. A circuit that alternates between a stable state and an unstable state.
 - C. A circuit set to block either a 0 pulse or a 1 pulse and pass the other.
 - D. A circuit that alternates between two unstable states.
29. What is a monostable multivibrator?
- A. A circuit that can be switched momentarily to the opposite binary state and then returns after a set time to its original state.
 - B. A "clock" circuit that produces a continuous square wave oscillating between 1 and 0.
 - C. A circuit designed to store one bit of data in either the 0 or the 1 configuration.
 - D. A circuit that maintains a constant output voltage, regardless of variations in the input voltage.
30. What is a bistable multivibrator circuit commonly named?
- A. AND gate.
 - B. OR gate.
 - C. Clock.
 - D. Flip-flop.

31. What is a bistable multivibrator circuit?
- A.** Flip-flop.
 - B. AND gate.
 - C. OR gate.
 - D. Clock.
32. What wave form would appear on the voltage outputs at the collectors of an astable, multivibrator, common-emitter stage?
- A. Sine wave.
 - B. Sawtooth wave.
 - C.** Square wave.
 - D. Half-wave pulses.
33. What is the name of the semiconductor memory IC whose digital data can be written or read, and whose memory word address can be accessed randomly?
- A. ROM – Read-Only Memory.
 - B. PROM – Programmable Read-Only Memory.
 - C.** RAM – Random-Access Memory.
 - D. EPROM – Electrically Programmable Read-Only Memory.
34. What is the name of the semiconductor IC that has a fixed pattern of digital data stored in its memory matrix?
- A. RAM – Random-Access Memory.
 - B.** ROM – Read-Only Memory.
 - C. Register.
 - D. Latch.
35. What does the term “IO” mean within a microprocessor system?
- A. Integrated oscillator.
 - B. Integer operation.
 - C.** Input-output.
 - D. Internal operation.
36. What is the name for a microprocessor’s sequence of commands and instructions?
- A.** Program.
 - B. Sequence.
 - C. Data string.
 - D. Data execution.
37. How many individual memory cells would be contained in a memory IC that has 4 data bus input/output pins and 4 address pins for connection to the address bus?
- A. 8
 - B. 16
 - C. 32
 - D.** 64

38. What is the name of the random-accessed semiconductor memory IC that must be refreshed periodically to maintain reliable data storage in its memory matrix?
- A. ROM – Read-Only Memory.
 - B. DRAM – Dynamic Random-Access Memory.**
 - C. PROM – Programmable Read-Only Memory.
 - D. PRAM – Programmable Random-Access Memory.
39. In a CHIP-8 program, address 0200H is selected. What decimal address is this?
- A. 512 decimal.**
 - B. 1024 decimal.
 - C. 2048 decimal.
 - D. There is no decimal equivalent.
40. What does the term “DAC” refer to in a microprocessor circuit?
- A. Dynamic access controller.
 - B. Digital to analog converter.**
 - C. Digital access counter.
 - D. Dial analog control.
41. Which of the following is not part of a MCU processor?
- A. RAM
 - B. ROM
 - C. I/O
 - D. Voltage Regulator**
42. What portion of a microprocessor circuit is the pulse generator?
- A. Clock**
 - B. RAM
 - C. ROM
 - D. PLL
43. In a microprocessor, what is the meaning of the term “ALU”?
- A. Automatic lock/unlock.
 - B. Arithmetic logic unit.**
 - C. Auto latch undo.
 - D. Answer local unit.
44. What circuit interconnects the microprocessor with the memory and input/output system?
- A. Control logic bus.
 - B. PLL line.
 - C. Data bus line.**
 - D. Directional coupler.

45. What is the purpose of a prescaler circuit?
- A. Converts the output of a JK flip-flop to that of an RS flip-flop.
 - B. Multiplies an HF signal so a low-frequency counter can display the operating frequency.
 - C. Prevents oscillation in a low frequency counter circuit.
 - D.** Divides an HF signal so that a low-frequency counter can display the operating frequency.
46. What does the term “BCD” mean?
- A. Binaural coded digit.
 - B. Bit count decimal.
 - C.** Binary coded decimal.
 - D. Broad course digit.
47. What is the function of a decade counter digital IC?
- A. Decode a decimal number for display on a seven-segment LED display.
 - B.** Produce one output pulse for every ten input pulses.
 - C. Produce ten output pulses for every input pulse.
 - D. Add two decimal numbers.
48. What integrated circuit device converts an analog signal to a digital signal?
- A. DAC
 - B. DCC
 - C.** ADC
 - D. CDC
49. What integrated circuit device converts digital signals to analog signals?
- A. ADC
 - B. DCC
 - C. CDC
 - D.** DAC
50. In binary numbers, how would you note the quantity TWO?
- A.** 0010
 - B. 0002
 - C. 2000
 - D. 0020